

# Infrared heat lamps

# Halogen for industrial process

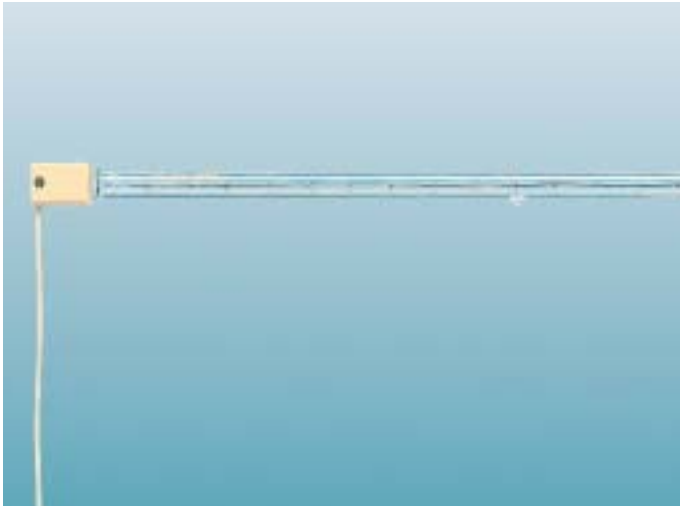

SK15 clear



R7S clear



U frosted



V clear



Y clear



CER + lead clear



X clear

Tubular, double-ended quartz infrared lamps are high-powered heat sources incorporating a tungsten filament within a quartz envelope. They are of the halogen type, which avoids blackening of the tube and consequently infrared depreciation throughout their whole lifetime.

Benefits of these lamps for industrial purposes include high efficiency, fast heat transfer, direct response to power control, compactness and light weight. Depending on their type, these lamps have a horizontal or universal burning position.

## Applications

- Paint drying in tunnels and body shops
- Blowing of PETP bottles
- Plastics thermoforming
- Epitaxy, CVD, RTP, Oxidation processes in semiconductor industry
- Heating of food and keeping it warm
- Paper drying in paper mills
- Drying of lacquer, printing inks
- Pre-heating of wood prior to lacquering
- Heat sterilization
- Softening, melting of plastics.

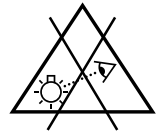

*Prolonged looking at the lamp during operation may result in damage to the eye.*

# Infrared heat lamps

# Halogen for industrial process

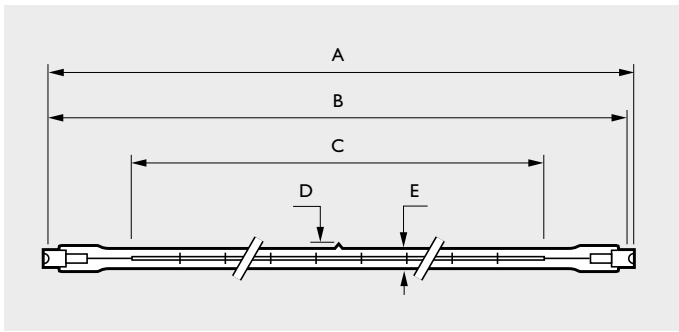

Fig. 1

| Type                | A<br>max. | B         | C         | D<br>max. | E<br>max. |
|---------------------|-----------|-----------|-----------|-----------|-----------|
| <b>Cap/base R7s</b> |           |           |           |           |           |
| 375T3/7             | 217.6     | 214.0±1.6 | 127.0±5.0 | 0         | 11        |
| 500T3/7             | 217.6     | 214.0±1.6 | 127.0±5.0 | 0         | 11        |
| 1600T3/7            | 498.6     | 494.0±1.6 | 406.0±5.0 | 0         | 11        |
| 2500T3/7            | 730.0     | 724.0±1.6 | 635.0±5.0 | 0         | 11        |
| 13169R              | 220.6     | 217.2±1.6 | 165.0±5.0 | 5         | 11        |
| 13908R              | 117.6     | 114.2±1.6 | 60.0±5.0  | 5         | 11        |

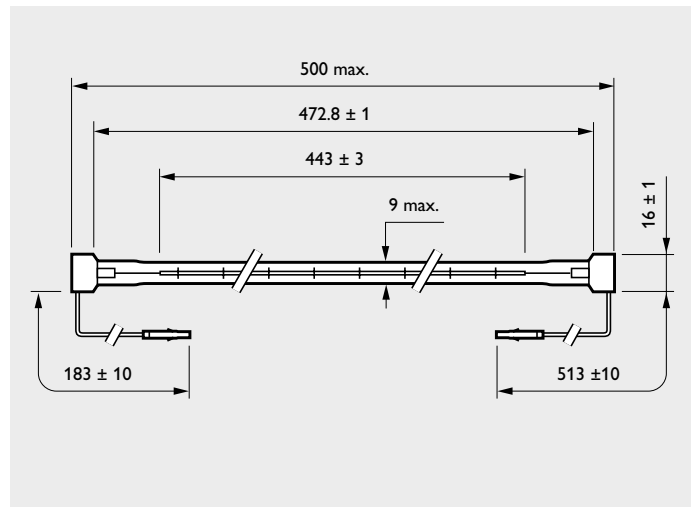

Fig. 2 - 13296C/13298C SK11

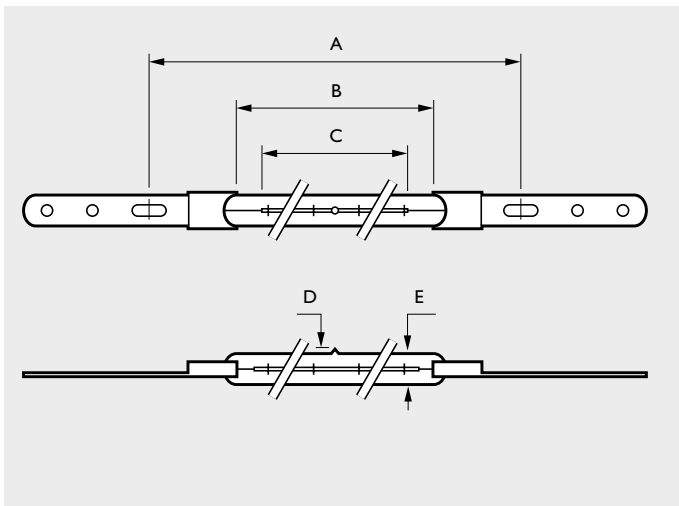

Fig. 3

| Type              | A      | B<br>min. | C     | D<br>max. | E<br>max. |
|-------------------|--------|-----------|-------|-----------|-----------|
| <b>Cap/base X</b> |        |           |       |           |           |
| 13168X            | 370±10 | 295       | 280±5 | 5         | 11.0      |
| 13169X            | 241±10 | 165       | 142±5 | 0         | 11.0      |
| 13195X            | 370±10 | 295       | 272±5 | 5         | 11.0      |
| 13230X            | 798±10 | 725       | 700±5 | 5         | 11.0      |
| 13245X            | 508±10 | 435       | 410±5 | 0         | 11.0      |
| 13565X            | 370±10 | 291       | 277±5 | 5         | 13.5      |
| 13713X            | 370±10 | 295       | 272±5 | 5         | 11.0      |
| 13765X            | 508±10 | 435       | 410±5 | 5         | 11.0      |
| 13169X/98         | 241±10 | 165       | 142±5 | 0         | 11.0      |
| 13195X/98         | 370±10 | 295       | 272±5 | 5         | 11.0      |
| 13230X/98         | 798±10 | 725       | 700±5 | 5         | 11.0      |
| 13245X/98         | 508±10 | 435       | 410±5 | 0         | 11.0      |
| 13713X/98         | 370±10 | 295       | 272±5 | 5         | 11.0      |
| 13765X/98         | 508±10 | 435       | 410±5 | 5         | 11.0      |

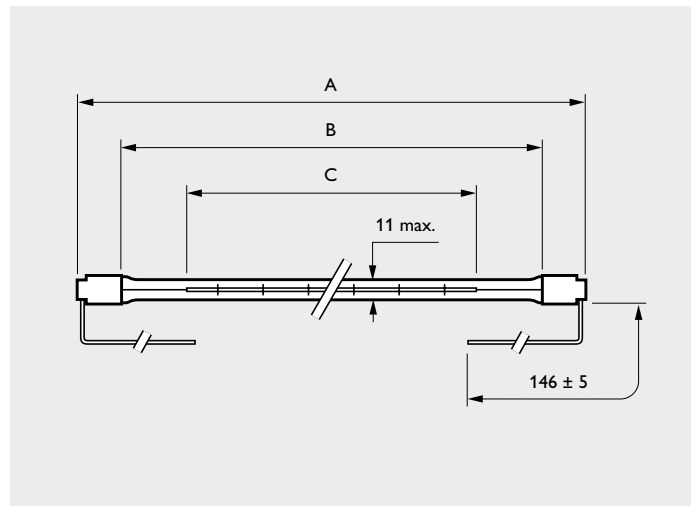

Fig. 4

Dimensions in mm

| Type              | A<br>max. | B      | C     |
|-------------------|-----------|--------|-------|
| <b>Cap/base U</b> |           |        |       |
| 2MT3/1CL/HT/UB/O  | 303.0     | 265±2  | 254±5 |
| 500T3             | 223.8     | 187±2  | 127±5 |
| 1000T3            | 351.0     | 313±2  | 254±5 |
| 1600T3            | 503.0     | 467±2  | 406±5 |
| 1600T3/CL         | 503.0     | 467±2  | 406±5 |
| 2500T3            | 731.0     | 694±2  | 635±5 |
| 2500T3/CL         | 731.0     | 694±2  | 635±5 |
| 3200T3/CL         | 1062.0    | 1025±2 | 815±5 |
| 3800T3            | 1062.0    | 1025±2 | 965±5 |
| 3800T3/CL/UB      | 1062.0    | 1025±2 | 965±5 |
| 5000T3/1CL/HT     | 731.0     | 694±2  | 635±5 |

# Infrared heat lamps

# Halogen for industrial process

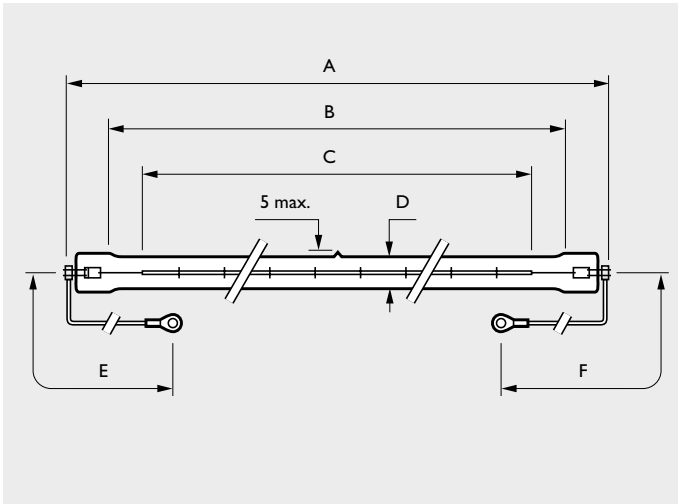

Fig. 5

| Type       | A max. | B     | C     | D max. | E     | F     |
|------------|--------|-------|-------|--------|-------|-------|
| Cap/base V |        |       |       |        |       |       |
| 13168V     | 350    | 309±2 | 280±5 | 12.0   | 117±5 | 138±5 |
| 13565V     | 350    | 309±2 | 280±5 | 13.5   | 117±5 | 138±5 |

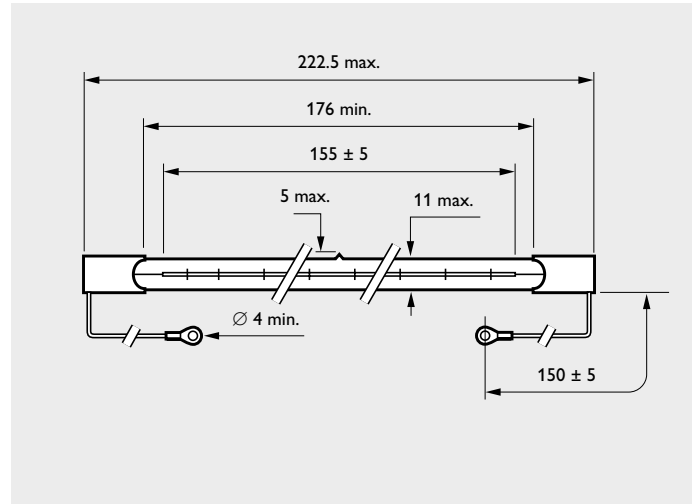

Fig. 6 - 13561Y/00, 13568Y/00

Dimensions in mm

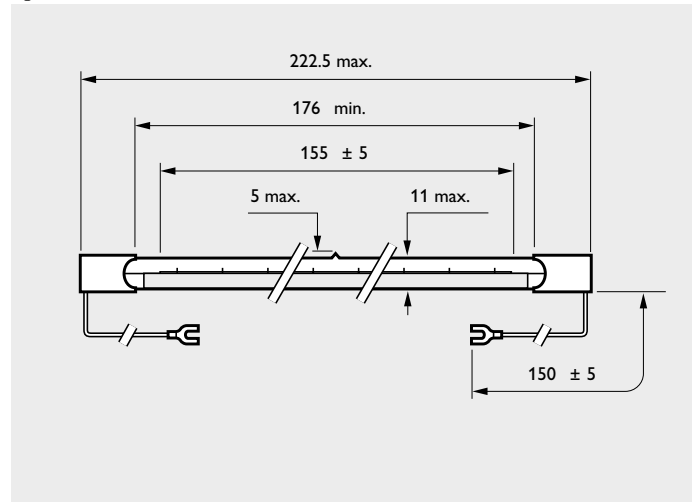

Fig. 7 - 13561Y/98, 13568Y/98

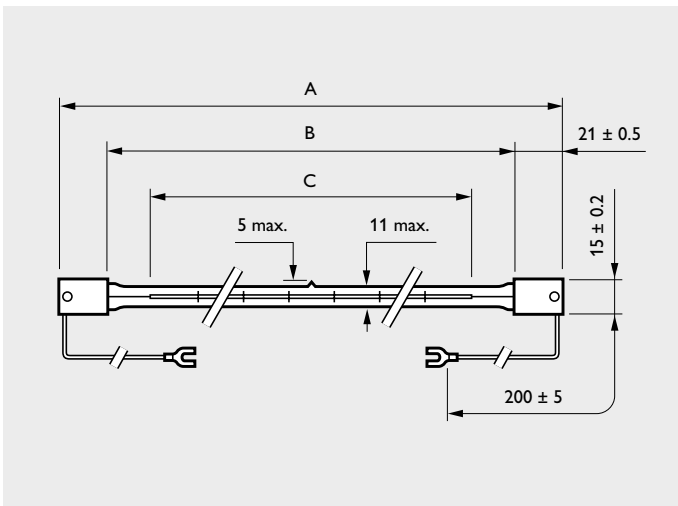

Fig. 8

| Type          | A max. | B       | C     |
|---------------|--------|---------|-------|
| Cap/base SK15 |        |         |       |
| 13169Z        | 227.5  | 180.0±2 | 165±5 |
| 13169Z/98     | 227.5  | 180.0±2 | 165±5 |
| 13713Z/98     | 357.5  | 310.0±3 | 272±5 |
| 13168Z/98     | 357.5  | 310.0±3 | 280±5 |
| 13393Z        | 787.5  | 740.0±3 | 700±5 |
| 13195Z/98     | 357.5  | 310.0±3 | 272±5 |

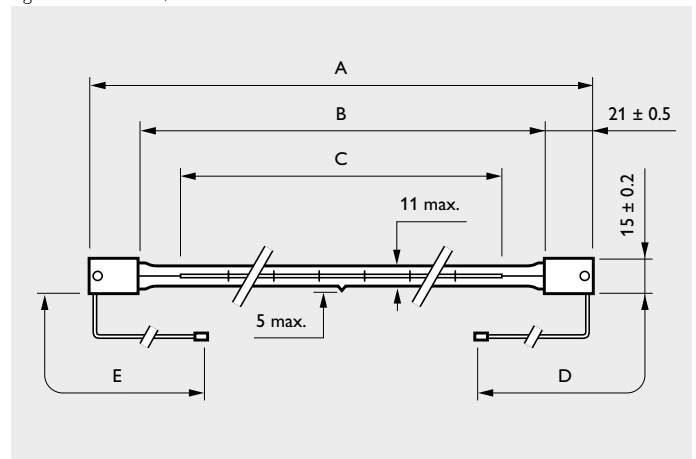

Fig. 9

| Type          | A max. | B     | C     | D     | E      |
|---------------|--------|-------|-------|-------|--------|
| Cap/base SK15 |        |       |       |       |        |
| 14103Z/98     | 357.5  | 310±3 | 280±5 | 230±5 | 230±5  |
| 14117Z        | 787.5  | 740±3 | 700±5 | 230±5 | 1200±5 |
| 13842Z        | 213.0  | 170±3 | 150±5 | 140±5 | 140±5  |
| 13214Z/98     | 658.0  | 604±3 | 500±5 | 500±5 | 500±5  |
| 14107Z/98     | 787.5  | 740±3 | 700±5 | 500±5 | 500±5  |



| Type   | Wattage | Voltage | Fig. | Max. overall length | Heating length | Cap/base | Finish      | Burning position | Lamp life 50% h | Ordering number | EOC    |
|--|---------|---------|------|---------------------|----------------|----------|-------------|------------------|-----------------|-----------------|--------|
|  | W       | V       |      | mm                  | mm             |          |             |                  |                 |                 |        |
| <b>GENERAL INDUSTRIAL COLOUR TEMPERATURE 2450K</b>       |         |         |      |                     |                |          |             |                  |                 |                 |        |
| 13169X   | 500W    | 120V    | 3    | 241.0               | 142.0          | X        | CLEAR       | P15              | 5000            | 9238 500 32300  | 216793 |
| 13169X/98  | 500W    | 120V    | 3    | 241.0               | 142.0          | X        | REFLECTOR   | P15              | 5000            | 9238 502 32300  | 217400 |
| 500T3  | 500W    | 120V    | 4    | 223.8               | 127.0          | U        | TRANSLUCENT | P15              | 5000            | 9245 176 36300  | 517630 |
| 13169Z   | 500W    | 235V    | 8    | 227.5               | 165.0          | SK15     | CLEAR       | P15              | 5000            | 9245 308 44500  | 497338 |
| 13169Z/98  | 500W    | 235V    | 8    | 227.5               | 165.0          | SK15     | REFLECTOR   | P15              | 5000            | 9238 527 44500  | 217417 |
| 13842Z   | 700W    | 240V    | 9    | 213.0               | 150.0          | SK15     | CLEAR       | P15              | 5000            | 9245 270 45500  | 496089 |
| 13195Z/98  | 1000W   | 235V    | 8    | 357.5               | 272.0          | SK15     | REFLECTOR   | P15              | 5000            | 9238 543 44500  | 217455 |
| 13195X   | 1000W   | 235V    | 3    | 370.0               | 272.0          | X        | CLEAR       | P15              | 5000            | 9238 510 43900  | 217424 |
| 13195X/98  | 1000W   | 235V    | 3    | 370.0               | 272.0          | X        | REFLECTOR   | P15              | 5000            | 9238 514 43900  | 519429 |
| 13713X   | 1000W   | 235V    | 3    | 370.0               | 272.0          | X        | CLEAR       | UNIVERSAL        | 5000            | 9238 515 43900  | 214720 |
| 13713X/98  | 1000W   | 235V    | 3    | 370.0               | 272.0          | X        | REFLECTOR   | UNIVERSAL        | 5000            | 9238 960 44500  | 214737 |
| 13713Z/98  | 1000W   | 235V    | 8    | 357.5               | 272.0          | SK15     | REFLECTOR   | UNIVERSAL        | 5000            | 9238 535 44500  | 214744 |
| 1000T3   | 1000W   | 240V    | 4    | 351.0               | 254.0          | U        | TRANSLUCENT | P15              | 5000            | 9245 178 43800  | 517654 |
| 13561Y/00  | 1200W   | 144V    | 6    | 222.5               | 155.0          | Y        | CLEAR       | P15              | 5000            | 9239 207 57700  | 491572 |
| 13561Y/98  | 1200W   | 144V    | 7    | 222.5               | 155.0          | Y        | REFLECTOR   | P15              | 5000            | 9245 033 57700  | 055699 |
| 13568Y/00  | 1600W   | 144V    | 6    | 222.5               | 155.0          | Y        | CLEAR       | P15              | 5000            | 9239 457 57700  | 491596 |
| 13568Y/98  | 1600W   | 144V    | 7    | 222.5               | 155.0          | Y        | REFLECTOR   | P15              | 5000            | 9245 032 57700  | 055682 |
| 1600T3   | 1600W   | 240V    | 4    | 503.0               | 406.0          | U        | TRANSLUCENT | P15              | 5000            | 9245 182 45500  | 051769 |
| 1600T3/CL  | 1600W   | 240V    | 4    | 503.0               | 406.0          | U        | CLEAR       | P15              | 5000            | 9245 181 43800  | 517685 |
| 14103Z/98  | 2000W   | 235V    | 9    | 357.5               | 280.0          | SK15     | REFLECTOR   | P15              | 5000            | 9245 347 44900  | 498342 |
| 13168V   | 2000W   | 235V    | 5    | 350.0               | 280.0          | V        | CLEAR       | UNIVERSAL        | 5000            | 9238 504 44500  | 496324 |
| 13168X   | 2000W   | 235V    | 3    | 370.0               | 280.0          | X        | CLEAR       | UNIVERSAL        | 5000            | 9238 525 43900  | 216779 |
| 13168Z/98  | 2000W   | 235V    | 8    | 357.5               | 280.0          | SK15     | REFLECTOR   | UNIVERSAL        | 5000            | 9238 536 44500  | 216786 |
| 2MT3/ICL/HT/UBO  | 2000W   | 240V    | 4    | 303.0               | 254.0          | U        | CLEAR       | UNIVERSAL        | 5000            | 9245 185 45500  | 517722 |
| 13214Z/98  | 2000W   | 230V    | 9    | 658.0               | 500.0          | SK15     | REFLECTOR   | P15              | 5000            | 9245 323 44200  | 498236 |
| 13245X   | 2000W   | 400V    | 3    | 508.0               | 410.0          | X        | CLEAR       | P15              | 5000            | 9238 530 57900  | 496331 |
| 13245X/98  | 2000W   | 400V    | 3    | 508.0               | 410.0          | X        | REFLECTOR   | P15              | 5000            | 9238 529 57900  | 214706 |
| 13765X   | 2000W   | 400V    | 3    | 508.0               | 410.0          | X        | CLEAR       | UNIVERSAL        | 5000            | 9238 531 57900  | 214751 |
| 13765X/98  | 2000W   | 400V    | 3    | 508.0               | 410.0          | X        | REFLECTOR   | UNIVERSAL        | 5000            | 9245 054 57900  | 055750 |
| 2500T3   | 2500W   | 480V    | 4    | 731.0               | 635.0          | U        | TRANSLUCENT | P15              | 5000            | 9245 183 51600  | 517708 |
| 2500T3/CL  | 2500W   | 480V    | 4    | 731.0               | 635.0          | U        | CLEAR       | P15              | 5000            | 9245 264 51600  | 517807 |
| 14107Z/98  | 3000W   | 230V    | 9    | 787.5               | 700.0          | SK15     | REFLECTOR   | P15              | 5000            | 9245 363 44200  | 498526 |
| 13565V   | 3000W   | 235V    | 5    | 350.0               | 277.0          | V        | CLEAR       | UNIVERSAL        | 5000            | 9245 143 44500  | 055941 |
| 13565X   | 3000W   | 235V    | 3    | 370.0               | 277.0          | X        | CLEAR       | UNIVERSAL        | 5000            | 9239 456 44500  | 055330 |
| 13230X   | 3000W   | 400V    | 3    | 798.0               | 700.0          | X        | CLEAR       | UNIVERSAL        | 5000            | 9238 540 57900  | 217486 |
| 13230X/98  | 3000W   | 400V    | 3    | 798.0               | 700.0          | X        | REFLECTOR   | UNIVERSAL        | 5000            | 9238 541 57900  | 217493 |
| 3200T3/CL  | 3200W   | 240V    | 4    | 1062.0              | 815.0          | U        | CLEAR       | P15              | 5000            | 9245 326 45500  | 001689 |
| 3800T3   | 3800W   | 575V    | 4    | 1062.0              | 965.0          | U        | TRANSLUCENT | P15              | 5000            | 9245 184 51100  | 517715 |
| 3800T3/CL/UB   | 3800W   | 575V    | 4    | 1062.0              | 965.0          | U        | CLEAR       | UNIVERSAL        | 5000            | 9245 173 51100  | 517616 |
| <b>LOW COLOUR TEMPERATURE LAMPS 2000K</b>                |         |         |      |                     |                |          |             |                  |                 |                 |        |
| 13296C   | 400W    | 110V    | 2    | 500.0               | 443.0          | SK11     | CLEAR       | P4               | 5000            | 9239 470 31900  | 055378 |
| 13298C   | 630W    | 110V    | 2    | 500.0               | 443.0          | SK11     | CLEAR       | P4               | 5000            | 9245 012 31900  | 055675 |
| 14117Z   | 750W    | 230V    | 9    | 787.5               | 700.0          | SK15     | CLEAR       | UNIVERSAL        | 5000            | 9245 405 44216  | 518569 |
| 13393Z   | 1300W   | 235V    | 8    | 787.5               | 700.0          | SK15     | CLEAR       | UNIVERSAL        | 5000            | 9239 454 44500  | 055323 |
| <b>OTHER APPLICATIONS COLOUR TEMPERATURE 2450K - R7S</b> |         |         |      |                     |                |          |             |                  |                 |                 |        |
| 13908R   | 300W    | 230V    | 1    | 117.6               | 60.0           | R7S      | CLEAR       | P15              | 1000            | 9238 503 43300  | 491558 |
| 375T3/7  | 375W    | 120V    | 1    | 217.6               | 127.0          | R7S      | TRANSLUCENT | P15              | 5000            | 9245 205 34600  | 517784 |
| 500T3/7  | 500W    | 120V    | 1    | 217.6               | 127.0          | R7S      | TRANSLUCENT | P15              | 5000            | 9245 177 34600  | 517647 |
| 13169R   | 500W    | 235V    | 1    | 220.6               | 165.0          | R7S      | CLEAR       | P15              | 5000            | 9239 468 44500  | 055354 |
| 1600T3/7   | 1600W   | 240V    | 1    | 498.6               | 406.0          | R7S      | TRANSLUCENT | P15              | 5000            | 9245 190 43800  | 517760 |
| 2500T3/7   | 2500W   | 480V    | 1    | 730.0               | 635.0          | R7S      | TRANSLUCENT | P15              | 5000            | 9245 191 51600  | 517777 |

## Replacement table

| W    | Old type<br>Z cap | Corresponding new type<br>SK15 cap |
|------|-------------------|------------------------------------|
| 2000 | 13213Z/98F        | 14103Z/98                          |

# Infrared heat lamps

# Halogen for industrial process

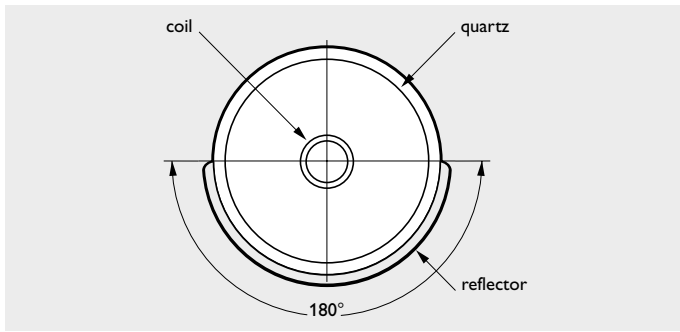

Cross-section of lamp with reflector I98

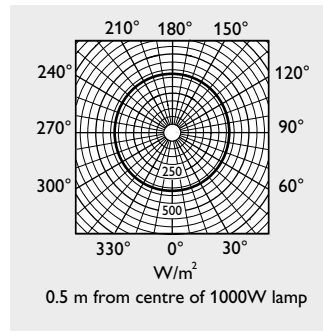

Without reflector

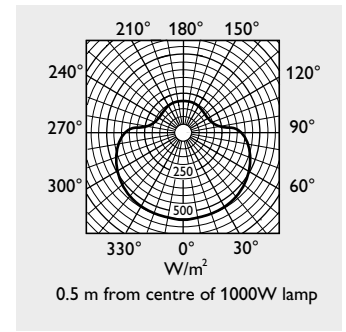

With reflector I98

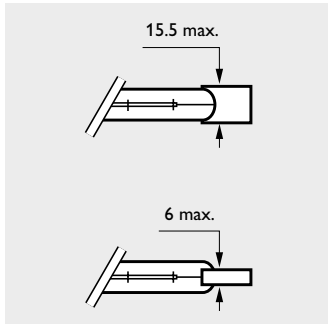

Detail of Y-version

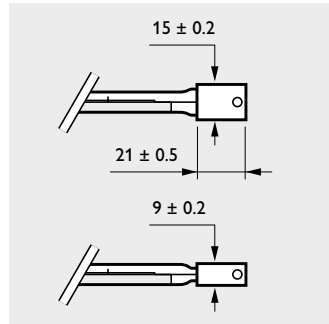

Detail of SK15-cap version

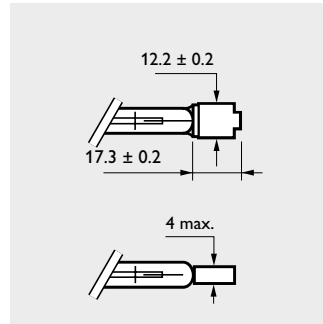

Detail of U-clip version

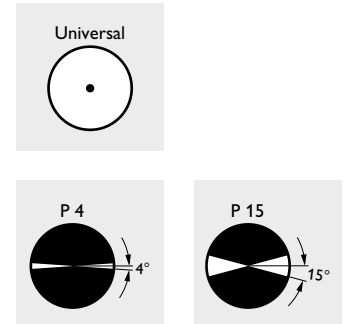

Burning positions

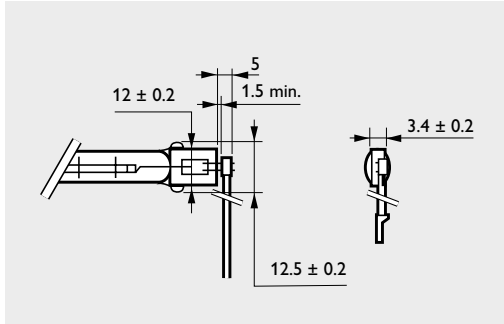

Detail of V-version

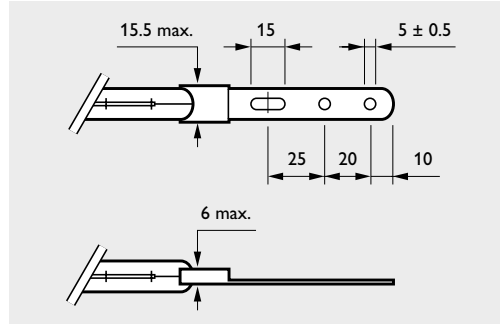

Detail of X-clip version

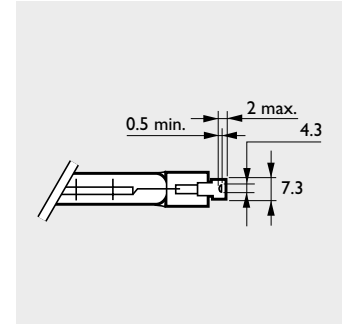

Detail of R7S-version

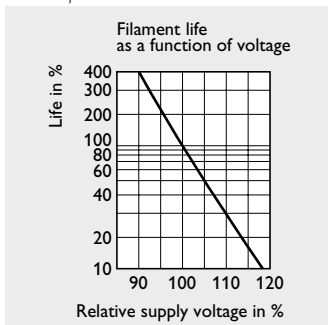

Special diagrams

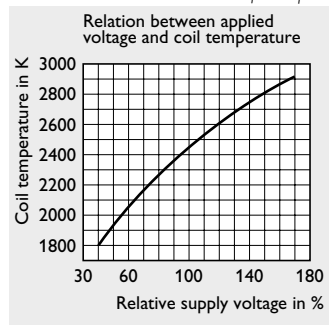

Remark: 100 % = 2450 K

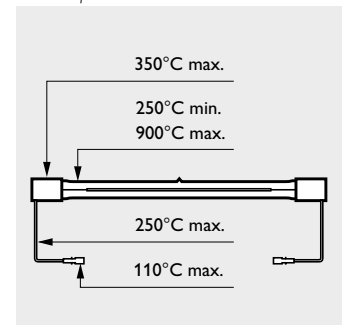
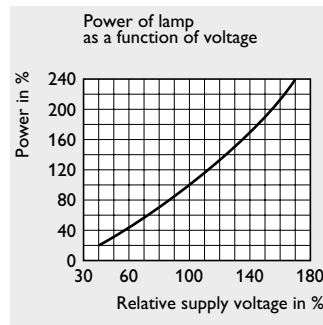

Permissible temperatures

Prolonged storage in high moisture warehouse may result in lamp depreciation. Philips Lighting is also able to meet special customer demands. If you have any questions, please contact your local Philips Lighting organisation.

